

CLP

空心式夾緊器

CLP HOLLOW CLAMP

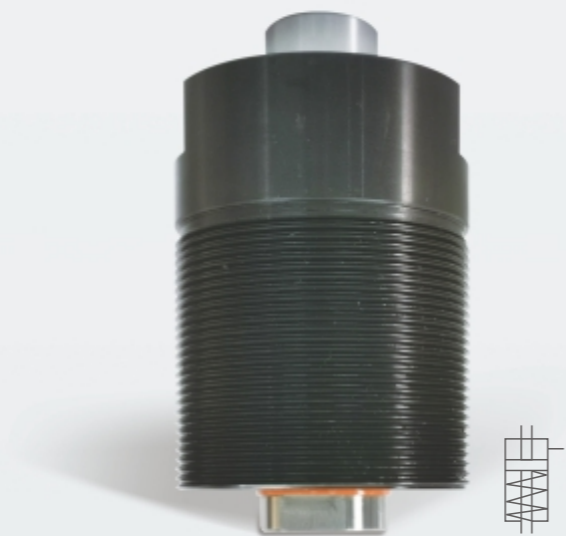

產品特性

主桿孔貫通,端部有內螺紋,根據安裝工位,可以用於拉開或推開的功能。

使用油壓範圍:15~250kgf/cm²
 活塞速度:8~100mm/s
 使用環境溫度:0~60°C
 油路盡量要大
 作動方式:單動式

FEATURES

There is a hole through the rod so bolts can be used,as there is a female screw at the end.Dependng on the mounting position, it can be used for pushing or pulling.

Operating Pressure:15~250kgf/cm².
 Piston Speed:8~100mm/s.
 Operating Temperature:0~60°C.
 Make piping size as big as possible.
 Single acting.

訂購標示法 ORDERING INDICATION

示例: CLP-2808

CLP	系列 Series	CLP
28	油缸內徑 Hydraulic cylinder inside diameter	28/40/63
08	行程 Stroke	08=8mm 12=12mm 20=20mm

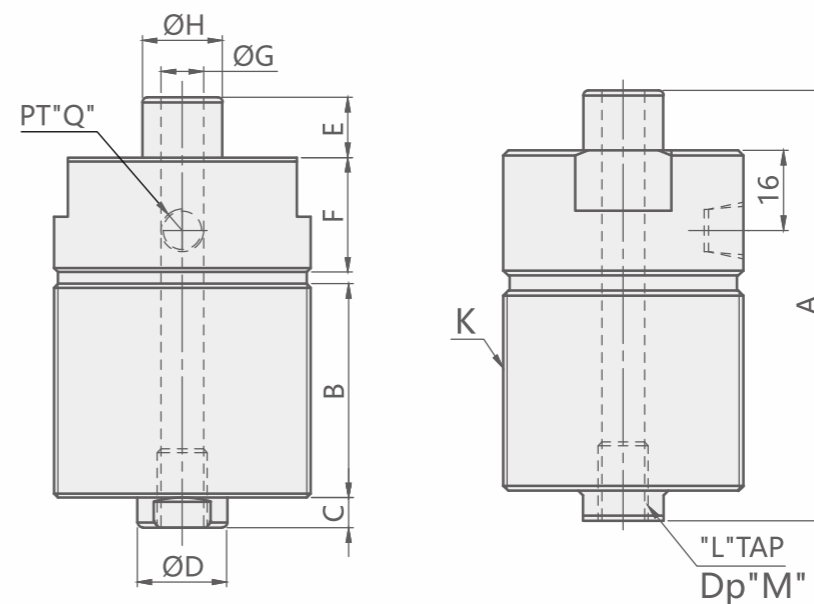
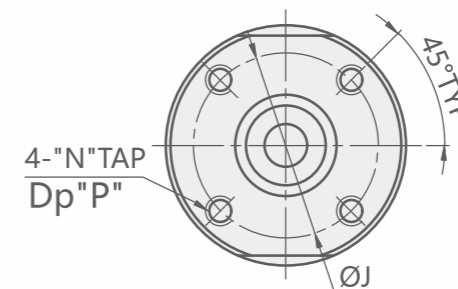

尺寸 Dimensions Unit:mm

MODEL NO.	CLP-2808	CLP-4012	CLP-6320
A	86	109	140
B	40	53	70
C	6	9	10
ØD	18	28	40
E	12	15	23
F	25	29	34
ØG	11	17	21
ØH	16	25	35
ØJ	37	50	70
K	M48x1.5P	M65x2.0P	M90x2.0P
L	M10x1.5P	M12x1.75P	M24x3.0P
M	15	20	32
N	M6x1.0P	M8x1.25P	M12x1.75P
P	10	16	18
Q	1/8	1/4	3/8

規格參數表 SPECIFICATIONS

型號	行程	油缸容量	油缸面積	最大夾緊力	內徑	重量
MODEL	STROKE (mm)	CYLINDER CAPACITY(cm ³)	CYLINDER AREA(cm ²)	MAXIMUM CLAMPING FORCE(kgf)	INSIDE DIAMETER(mm)	WEIGHT(kg)
CLP-2808	8	3.31	4.14	1000	Ø28	0.85
CLP-4012	12	9.18	7.65	1900	Ø40	1.91
CLP-6320	20	43.08	21.54	5300	Ø63	4.28