

CLL

油壓緊湊型直線缸

CLL HYDRAULIC COMPACT LINEAR CYLINDER



產品特性

以最小空間實現大的行程,CLL/CLLR/CLLU可以以1mm為單位指定行程,又可以在豐富組合中進行選擇。

FEATURES

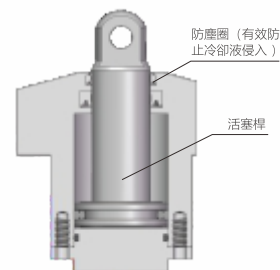

Maximum stroke is available with minimum space. CLL/CLLR/CLLU with 1 mm stroke increments and a variety of styles.

剖面圖 Sectional view



訂購標示法 ORDERING INDICATION

示例: CLL-048CA-050

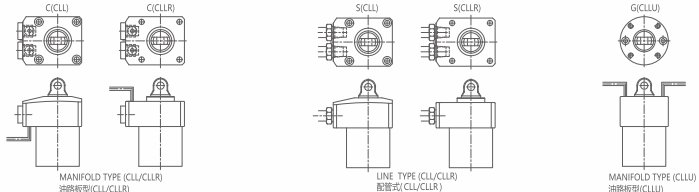
CLL	系列 Series	CLL					
	安裝方式 Mounting Methods	 CLL:法蘭下部安裝型 Top Flange	 CLLR:法蘭上部安裝型 Bottom Flange	 CLLU:法蘭上部安裝型 (節省空間型) Bottom Flange (Compact)			
048	本體尺寸 BodySize	036:ΦD=36 065:ΦD=65	040:ΦD=40 075:ΦD=75	048:ΦD=48 090:ΦD=90	055:ΦD=55 105:ΦD=105	註: ΦD是油缸本體外徑尺寸 Note: ΦD indicates the outer diameter of the Cylinder	
C	配管方式 Piping Method	C: 板式連接型 (附帶G螺紋堵頭, 對應CLL/CLLR型) S: 配管型 (Rc螺紋, 對應CLL/CLLR型) G: 板式連接型 (只有板式供油口, 對應CLLU型)		C: Gasket Option (With G Thread Plug, Apply to CLL/CLLR) S: Piping Option (Rc Thread Port, Apply to CLL/CLLR) G: Gasket Option (Gasket Port only, Apply to CLLU)			
A	活塞前端形狀 Shape of Piston Tip	A: 內螺紋型 T: 外螺紋型	B: 內螺紋型 (附帶旋轉防止銷孔) P: 銷孔連接型	A	B	T	P
050	行程 Stroke						



G:板式連接型 P:銷孔連接型 G: Gasket Option P:Pin-Hole Option
 ※本圖表示CLLU-GP型 ※ This drawing indicates CLLU-GP

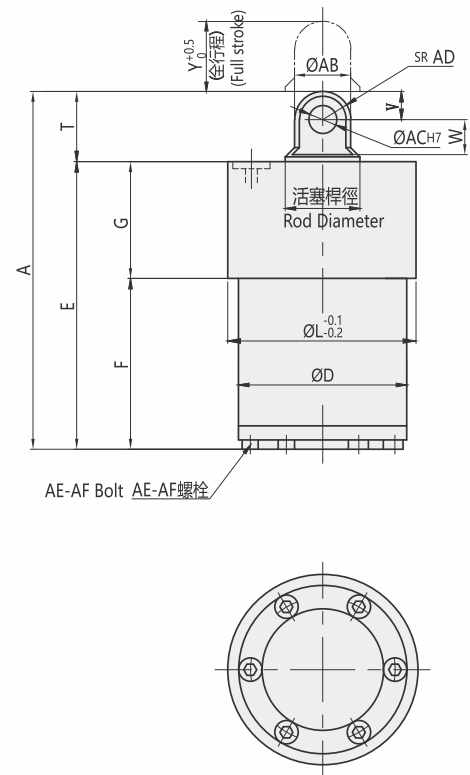
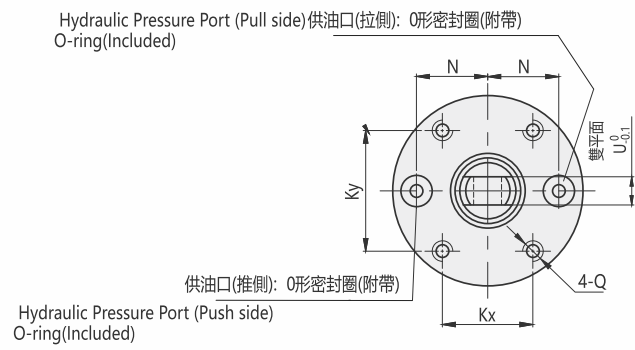

Tip Shape Refer P Pinhole dimension for not mentioned size below
 柱塞前端形狀 無記載的尺寸請參照銷孔連接型

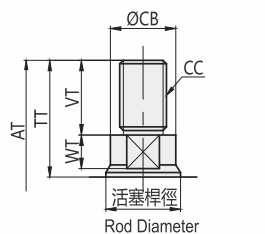
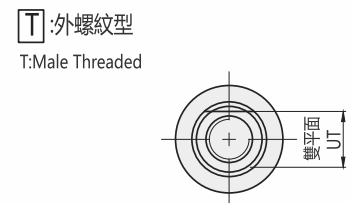
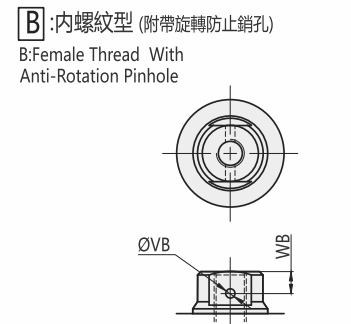
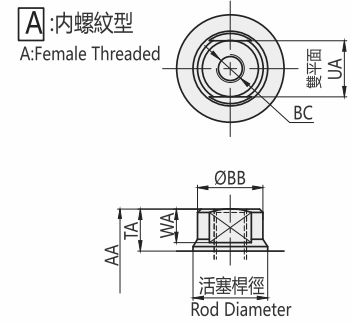

規格參數表 SPECIFICATIONS

型號 MODEL	總行程 Full Stroke Y (mm)	油缸面積 Cylinder Area(cm ²)		油缸輸出力 Cylinder force (計算公式) KN		油缸容量 (計算公式) Cylinder Capacity (Calculation Formula) cm ³		油缸內徑 Cylinder inside diameter (mm)	活塞桿徑 Rod Diameter(mm)	最高使用壓力 Max. Operating Pressure(Mpa)	最低動作壓力 Min. Operating Pressure(Mpa)	耐壓 Withstanding Pressure(Mpa)	使用溫度 Operating Temperature (°C)	重量 Weight (kg)
		推側 Push Side	拉側 Pull Side	推側 Push Side	拉側 Pull Side	推側 Push Side	拉側 Pull Side							
CLLU-036	1~50	4.5	2.5	P×0.45	P×0.25	Y×0.45	Y×0.25	Φ24	Φ16	7.0	0.5	10.5	0~70	0.6~0.8
CLLU-040	1~50	5.3	2.8	P×0.53	P×0.28	Y×0.53	Y×0.28	Φ26	Φ18	7.0	0.5	10.5	0~70	0.7~0.9
CLLU-048	1~75	8.0	4.9	P×0.80	P×0.49	Y×0.80	Y×0.49	Φ32	Φ20	7.0	0.5	10.5	0~70	1.0~1.6
CLLU-055	1~75	9.6	5.8	P×0.96	P×0.58	Y×0.96	Y×0.58	Φ35	Φ22	7.0	0.5	10.5	0~70	1.3~2.1
CLLU-065	1~75	15.9	11.0	P×1.59	P×1.10	Y×1.59	Y×1.10	Φ45	Φ25	7.0	0.5	10.5	0~70	1.9~3.1
CLLU-075	1~75	23.8	16.7	P×2.38	P×1.67	Y×2.38	Y×1.67	Φ55	Φ30	7.0	0.5	10.5	0~70	2.8~4.1
CLLU-090	1~75	36.3	26.4	P×3.63	P×2.64	Y×3.63	Y×2.64	Φ68	Φ35.5	7.0	0.5	10.5	0~70	4.3~6.1
CLLU-105	1~75	50.3	34.4	P×5.03	P×3.44	Y×5.03	Y×3.44	Φ80	Φ45	7.0	0.5	10.5	0~70	5.9~8.0

全行程 Y=1~14mm時, 外形尺寸與行程15mm時的油缸是一樣的 (例)
 CLLU-036GP -010 [Y=10, A=63, E=48, F=23] CLLU-036GP-030
 [Y=30, A=78, E=63, F=38]

※ Calculation formula is different between full stroke: Y=1-14 mm and
 Y= more than 15 mm.Ex.) CLLU-036GP-010 [Y=10, A=63, E=48, F=23
]CLLU-036GP-030 [Y=30, A=78, E=63, F=38]

P:銷孔連接型 Pin-Hole Option

Unit:mm

型號 Model	CLLU-036	CLLU-040	CLLU-048	CLLU-055	CLLU-065	CLLU-075	CLLU-090	CLLU-105
全行程 Full Stroke Y	1~14 15~50	1~14 15~50	1~14 15~75	1~14 15~75	1~14 15~75	1~14 15~75	1~14 15~75	1~14 15~75
A	63 Y+48	70 Y+55	74 Y+59	80 Y+65	90 Y+75	101 Y+86	114 Y+99	127 Y+112
D	36	40	48	55	65	75	90	105
E	48 Y+33	51 Y+36	53 Y+38	56 Y+41	62 Y+47	68 Y+53	77 Y+62	81 Y+66
F	23 Y+8	26 Y+11	25 Y+10	28 Y+13	32 Y+17	31 Y+16	37 Y+22	36 Y+21
G	25	25	28	28	30	37	40	45
Kx	23	24	27	30	36	42	54	65
Ky	30	32	36	40	48	56	64	65
L	45	48	53	60	70	83	100	116
N	17	18	20	22.5	27.5	32.5	39.5	46
Q (名稱×深度) (Nominal×Depth)	M4×0.7×8	M5×0.8×10	M5×0.8×10	M6×12	M6×12	M8×16	M10×20	M12×24
T	15	19	21	24	28	33	37	46
U	6	8	10	11	13	16	19	22
V	6	8	9	10	12	14	16	21
W	7.5	9.5	10.5	12	14	17	19	23
AB	12	15	17	19	22	27	32	42
AC	6 ^{+0.012} ₀	8 ^{+0.015} ₀	8 ^{+0.015} ₀	10 ^{+0.015} ₀	12 ^{+0.018} ₀	14 ^{+0.018} ₀	16 ^{+0.018} ₀	20 ^{+0.021} ₀
AD	6	8	9	10	12	14	16	21
AE	-	-	6	4	6	6	8	10
AF	-	-	M4×0.7	M5×0.8	M5×0.8	M6	M6	M6
O型密封圈 O-ring	1BP5	1BP5	1BP5	1BP5	1BP7	1BP7	1BP7	1BP7

A:內螺紋型 Female Threaded

Unit:mm

型號 Model	CLLU-036	CLLU-040	CLLU-048	CLLU-055	CLLU-065	CLLU-075	CLLU-090	CLLU-105
AA	57 Y+42	61 Y+46	64 Y+49	68 Y+53	75 Y+60	83 Y+68	93 Y+78	99 Y+84
TA	9	10	11	12	13	15	16	18
UA	12	13	14	17	19	24	30	36
WA	7.5	7.5	8.5	9	10	12	13	15
BB	14	15	17	19	22	27	33	42
BC(名稱×深度) (Nominal×Depth)	M6×12	M8×16	M8×16	M10×20	M12×24	M16×32	M20×40	M24×48

無記載的尺寸請參照P: 銷孔連接型。
 Refer P pinhole option dimension for not mentioned size below.

B:內螺紋型 (附帶旋轉防止銷孔) Female Threaded with Anti-Rotation Pin Hole

Unit:mm

型號 Model	CLLU-036	CLLU-040	CLLU-048	CLLU-055	CLLU-065	CLLU-075	CLLU-090	CLLU-105
VB	2	2.5	2.5	2.5	3	4	5	6
WB	5.5	5	6	6.5	7	8.5	9	10.5

無記載的尺寸請參照P: 銷孔連接型。A: 內螺紋型
 Refer P pinhole option / A female thread option, dimensions not mentioned size in the chart below

T:外螺紋型 Male Threaded

Unit:mm

型號 Model	CLLU-036	CLLU-040	CLLU-048	CLLU-055	CLLU-065	CLLU-075	CLLU-090	CLLU-105
AT	73 Y+58	81 Y+66	88 Y+73	96 Y+81	107 Y+92	118 Y+103	139 Y+124	153 Y+138
TT	25	30	35	40	45	50	62	72
UT	12	14	17	17	19	24	30	36
VT	16	20	24	28	32	35	46	54
WT	7.5	7.5	8.5	9	10	12	13	15
CB	14	17	19	21	24	29	34.5	42
CC(名稱×螺距) (Nominal×Pitch)	M10×1.25	M12×1.25	M14×1.5	M16×1.5	M20×1.5	M24×1.5	M30×1.5	M36×1.5

無記載的尺寸請參照P: 銷孔連接型。
 Refer P pinhole option dimension for not mentioned size below.

G:板式連接型 P:銷孔連接型 G: Gasket Option P:Pin-Hole Option
 ※本圖表示CLLU-GP型 ※ This drawing indicates CLLU-GP

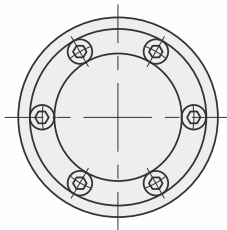
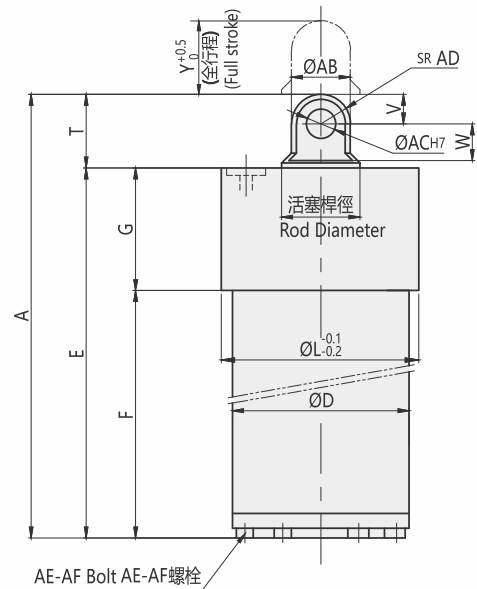
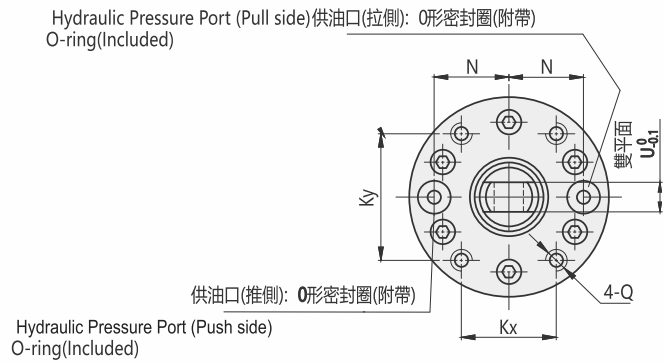

Tip Shape Refer P Pinhole dimension for not mentioned size below
 柱塞前端形狀 無記載的尺寸請參照銷孔連接型

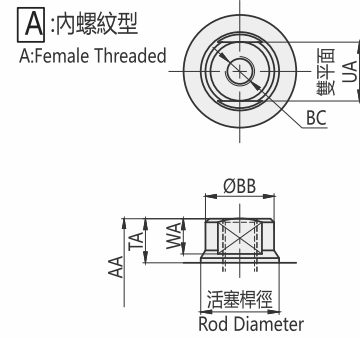

B:內螺紋型 (附帶旋轉防止銷孔)
 B:Female Thread With Anti-Rotation Pinhole

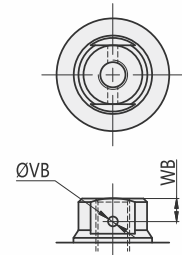

T:外螺紋型
 T:Male Threaded

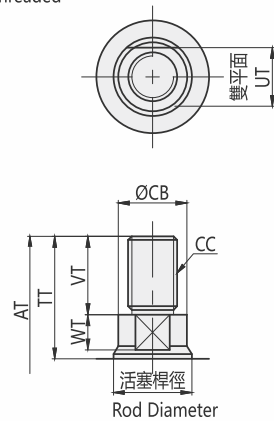

P:銷孔連接型 Pin-Hole Option

Unit:mm

型號 Model	CLLU-048	CLLU-055	CLLU-065	CLLU-075	CLLU-090	CLLU-105
全行程 Full Stroke Y	76~150	76~150	76~150	76~150	76~150	76~150
A	Y+76	Y+81	Y+91	Y+107	Y+121	Y+138
D	48	55	65	75	90	105
E	Y+55	Y+57	Y+63	Y+74	Y+84	Y+92
F	Y+27	Y+29	Y+33	Y+37	Y+44	Y+47
G	28	28	30	37	40	45
KX	27	30	36	42	54	65
KY	36	40	48	56	64	65
L	53	60	70	83	100	116
N	20	22.5	27.5	32.5	39.5	46
Q (名稱×深度) (Nominal×Depth)	M5×0.8×10	M6×12	M6×12	M8×16	M10×20	M12×24
T	21	24	28	33	37	46
U	10	11	13	16	19	22
V	9	10	12	14	16	21
W	10.5	12	14	17	19	23
AB	17	19	22	27	32	42
AC	8 ₀ ^{+0.015}	10 ₀ ^{+0.015}	12 ₀ ^{+0.018}	14 ₀ ^{+0.018}	16 ₀ ^{+0.018}	20 ₀ ^{+0.021}
AD	9	10	12	14	16	21
AE	6	4	6	6	8	10
AF	M4×0.7	M5×0.8	M5×0.8	M6	M6	M6
O型密封圈 O-ring	1BP5	1BP5	1BP7	1BP7	1BP7	1BP7

A:內螺紋型 Female Threaded

Unit:mm

型號 Model	CLLU-048	CLLU-055	CLLU-065	CLLU-075	CLLU-090	CLLU-105
AA	Y+66	Y+69	Y+76	Y+89	Y+100	Y+110
TA	11	12	13	15	16	18
UA	14	17	19	24	30	36
WA	8.5	9	10	12	13	15
BB	17	19	22	27	33	42
BC(名稱×深度) (Nominal×Depth)	M8×16	M10×20	M12×24	M16×32	M20×40	M24×48

無記載的尺寸請參照P: 銷孔連接型。
 Refer P pinhole option dimension for not mentioned size below.

B:內螺紋型 (附帶旋轉防止銷孔) Female Threaded with Anti-Rotation Pin Hole

Unit:mm

型號 Model	CLLU-048	CLLU-055	CLLU-065	CLLU-075	CLLU-090	CLLU-105
VB	2.5	2.5	3	4	5	6
WB	6	6.5	7	8.5	9	10.5

無記載的尺寸請參照P: 銷孔連接型。A: 內螺紋型
 Refer P pinhole option / A female thread option, dimensions not mentioned size in the chart below

T:外螺紋型 Male Threaded

Unit:mm

型號 Model	CLLU-048	CLLU-055	CLLU-065	CLLU-075	CLLU-090	CLLU-105
AT	Y+90	Y+97	Y+108	Y+124	Y+146	Y+164
TT	35	40	45	50	62	72
UT	17	17	19	24	30	36
VT	24	28	32	35	46	54
WT	8.5	9	10	12	13	15
CB	19	21	24	29	34.5	42
CC(名稱×螺距) (Nominal×Pitch)	M14×1.5	M16×1.5	M20×1.5	M24×1.5	M30×1.5	M36×1.5

無記載的尺寸請參照P: 銷孔連接型。
 Refer P pinhole option dimension for not mentioned size below.

規格參數表 SPECIFICATIONS

型號 Model	總行程 Full Stroke Y (mm)	油缸面積 Cylinder Area(cm ²)		油缸輸出力 (計算公式) Cylinder force (Calculation Formula) KN		油缸容量 (計算公式) Cylinder Capacity (Calculation Formula) cm ³		油缸內徑 Cylinder inside diameter (mm)	活塞桿徑 Rod Diameter(mm)	最高使用壓力 Max. Operating Pressure(Mpa)	最低動作壓力 Min. Operating Pressure(Mpa)	耐壓 Withstanding Pressure(Mpa)	使用溫度 Operating Temperature (°C)	重量 Weight (kg)
		推側 Push Side	拉側 Pull Side	推側 Push Side	拉側 Pull Side	推側 Push Side	拉側 Pull Side							
CLLU-048	76~150	8.0	4.9	P×0.80	P×0.49	Y×0.80	Y×0.49	Φ32	Φ20	7.0	0.5	10.5	0~70	1.7~2.3
CLLU-055	76~150	9.6	5.8	P×0.96	P×0.58	Y×0.96	Y×0.58	Φ35	Φ22	7.0	0.5	10.5	0~70	2.3~3.1
CLLU-065	76~150	15.9	11.0	P×1.59	P×1.10	Y×1.59	Y×1.10	Φ45	Φ25	7.0	0.5	10.5	0~70	3.2~4.1
CLLU-075	76~150	23.8	16.7	P×2.38	P×1.67	Y×2.38	Y×1.67	Φ55	Φ30	7.0	0.5	10.5	0~70	4.4~5.3
CLLU-090	76~150	36.3	26.4	P×3.63	P×2.64	Y×3.63	Y×2.64	Φ68	Φ35.5	7.0	0.5	10.5	0~70	6.5~7.6
CLLU-105	76~150	50.3	34.4	P×5.03	P×3.44	Y×5.03	Y×3.44	Φ80	Φ45	7.0	0.5	10.5	0~70	9.0~9.8